

REMINGTON FIELD SERVICE MANUAL

The Remington Nylon 77 is a 22 caliber automatic rifle chambered for long rifle cartridges only. The autoloading action, after firing, will open and the fired case will be ejected. The action will then close, cock and reload. The clip magazine has a capacity of five (5) cartridges. Extra clips of both five (5) and ten (10) shot capacity are available.

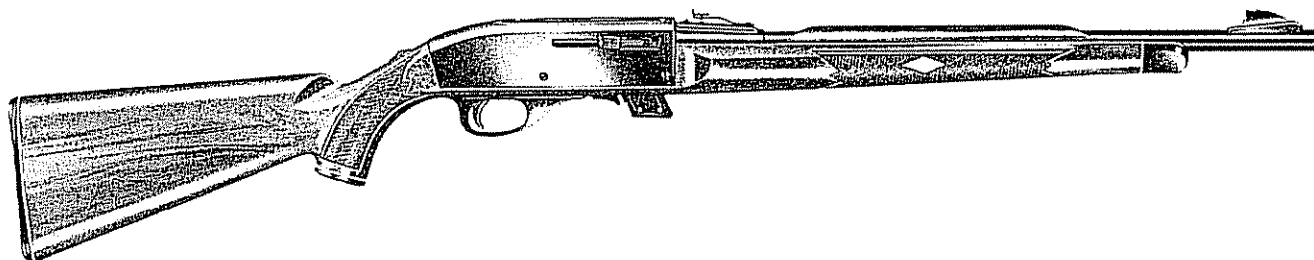

The naturally smooth qualities of Du Pont nylon provide bearing surfaces for the action and breech parts. Light lubrication for preservation on metal surfaces is all that is required.

Please package carefully if rifle is to be returned for factory service. Make sure all live ammunition is removed from magazine and barrel chamber.

See exploded view and parts list for identification of parts.

Note: Unless otherwise described, all parts are interchangeable with no factory assembly required.

INDEX

	Page		Page
Bolt Handle	1	Sear, Sear Spring (Sear Assembly Pin)	3
Receiver Cover Assembly	1	Disconnecter Assembly	3
Barrel Assembly	1	Safety Assembly	3
Front Sight	1	Safety Detent Ball - Safety Detent Spring	4
Ejector	1	Stock Assembly	4
Barrel Bracket Assembly	1	Rear Cover Screw Bushing	4
Bolt Assembly	1	Magazine Assembly	4
Bolt Assembly, Components	2	Magazine Guide - Magazine Latch	4
Action Spring Plunger - Action Spring	2	Magazine Latch Thumbpiece - Magazine Guide Screw	4
Firing Pin Striker	2	Malfunctions	4
Firing Pin Striker Spring	2	Parts List	5
Striker Spring Sleeve	2	Exploded View	6
Trigger Guard	2	Cycle Of Operation	8
Trigger, Complete	3		

Send all guns for factory service and inquiries on
service and parts to
REMINGTON ARMS COMPANY, INC.
Arms Service Division
Ilion, New York 13357

All other inquiries are to be addressed to
REMINGTON ARMS COMPANY, INC.
Bridgeport, Connecticut 06602

NYLON 77

BOLT HANDLE

To Disassemble — Cock rifle. Push safety rearward to ON SAFE position. Pull outward on bolt handle and remove. **Note:** A spring loaded action spring plunger locates into the shallow detent on stem of handle and holds handle assembled to bolt.

To Reassemble — Push bolt handle into hole in bolt until handle locates properly against action spring plunger.

RECEIVER COVER ASSEMBLY

To Disassemble — Cock rifle. Push safety ON SAFE. Pull out bolt handle. Unscrew and pull out cover screw (2). Lift up receiver cover assembly and remove from rifle.

To Replace — Replacement as an assembly is recommended. The receiver cover assembly is factory-listed to include: cartridge feed guide spring assembly, receiver cover shell assembly, rear sight assembly, rear sight rivet, windage screw. Special factory processes assemble the components to the receiver cover shell.

Components of the receiver cover assembly are factory processed as follows:

Cartridge feed guide spring is assembled first to receiver cover shell. **Cartridge feed guide rivet** is inserted from top of cover shell and staked at underside to hold cartridge feed guide spring in secure assembly to receiver cover shell.

Rear Sight Assembly is assembled next to receiver cover shell. **Rear sight rivet** is inserted from top of cover shell and staked at underside to hold rear sight assembly and windage screw in secure assembly to cover shell. However, before rear sight assembly is riveted to cover shell, the **elevation screw** must be assembled to the rear sight. Thread elevation screw to rear sight. Assemble elevation screw washer to end of elevation screw protruding from base of rear sight. Crimp end of screw over washer from bottom to hold elevation screw assembled to rear sight. Rear sight then should thread up and down freely as the elevation screw is turned.

Receiver cover screw lug (2) is inserted to the receiver cover shell. A staking operation from the inside holds the screw lug assembled to the cover shell.

To Reassemble — Make sure cartridge feed guide on bolt lies forward upon barrel. Make certain also that ejector (free fit), remains assembled to left side of rifle. Slide receiver cover assembly into place. Hold rear of cover down firmly in place. Assemble and tighten front and rear cover screws.

BARREL ASSEMBLY (includes front sight)

To Disassemble — Cock rifle and push safety ON SAFE. Remove bolt handle and receiver cover assembly. Reassemble bolt handle to bolt. Unscrew **barrel lock screw** a number of turns until nearly removable. Push upward on loosened screw until barrel bracket assembly slides upward in stock and clear of bracket slot in barrel. Pull loosened barrel forward and remove from rifle. See Fig. 1.

To Reassemble — Follow reverse order. Make certain barrel bracket assembly is located correctly in bracket slot of barrel and tightened down securely in stock by barrel lock screw. Make certain also that ejector remains assembled to left side under receiver cover assembly.

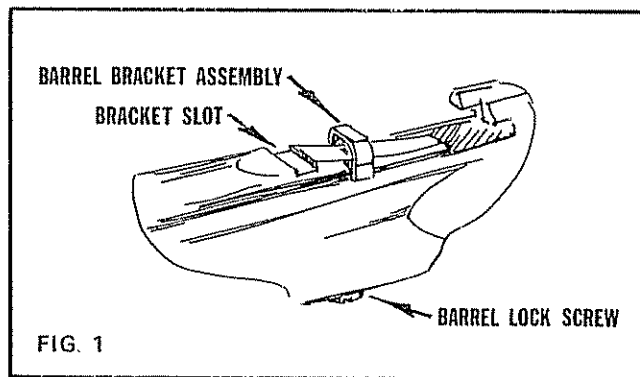

FRONT SIGHT

To Disassemble — Unscrew front sight screw (2). Lift front sight from barrel. Take care that small front sight washers (2) of white nylon material, located beneath front sight screw heads, are not lost.

To Reassemble — Follow reverse order.

EJECTOR

To Disassemble — Remove bolt handle and receiver cover assembly. Ejector can then be easily removed from a free-fit location in exposed left side of stock. See Fig. 2.

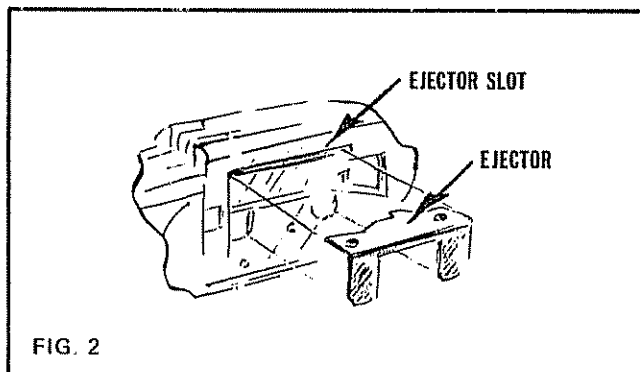

To Reassemble — Follow reverse order.

BARREL BRACKET ASSEMBLY

To Disassemble — Remove bolt handle and receiver cover assembly. Remove barrel and barrel lock screw from rifle. Lift up and pull barrel bracket assembly from recoil position in stock. See Fig. 3.

To Reassemble — Follow reverse order. Make certain barrel support slides freely on stud of barrel bracket.

BOLT ASSEMBLY

To Disassemble — Cock rifle and push safety ON SAFE. Remove bolt handle, receiver cover assembly, barrel and barrel bracket assembly. Pull bolt assembly forward and remove from rifle.

To Reassemble — Follow reverse order.

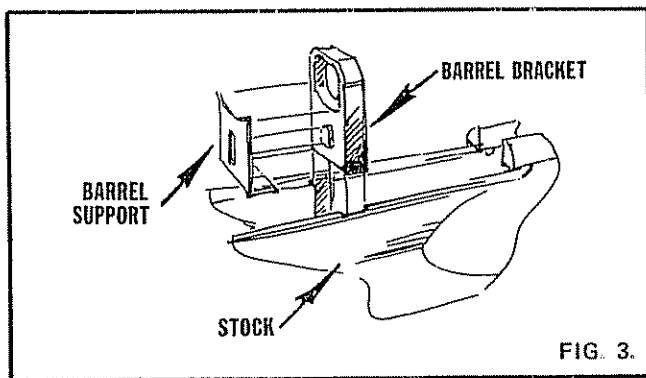

BOLT ASSEMBLY COMPONENTS Includes Bolt Sub Assembly, Cartridge Feed Guide, Extractor, Extractor Plunger, Extractor Spring, Firing Pin, Firing Pin Retaining Pin, Firing Pin Retractor Spring, Firing Pin Stop Pin.

To Disassemble — Remove bolt assembly. Insert small tool between rear of extractor and head of extractor plunger. Push back extractor plunger. Force rear of extractor upward and past plunger. Rotate claw of extractor inward and remove extractor from bolt.

Caution: Extractor is under spring tension during removal of extractor. Hold to prevent loss. Pull out loosened extractor plunger and remove from bolt. Pull or shake out loosened extractor spring and remove from bolt.

Firing pin may or may not be disassembled. Drive out firing pin stop pin. Note split roll design of stop pin for self tightening. Remove cartridge feed guide from bolt. See Fig. 4.

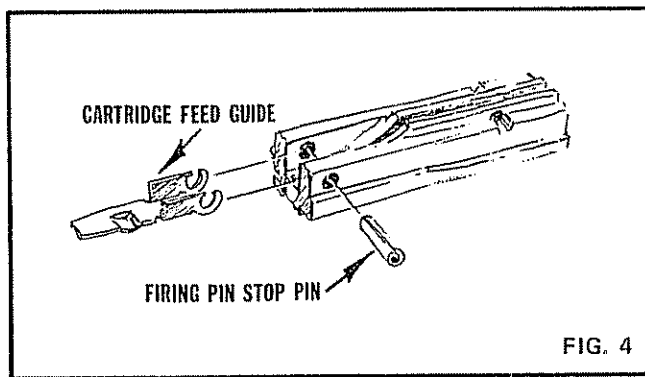

Straighten firing pin retaining pin. Pull out retaining pin and remove from bolt. Firing pin stop pin need not be removed. Lift up and remove firing pin from bolt. **CAUTION:** Firing pin retractor spring is assembled in "free assembly" within oblong opening at rear of firing pin. Remove firing pin retractor spring from "free assembly" position in rear of firing pin.

To Replace — Check extractor for firm hook or claw tension. Use fired case. Slight adjustment to firing pin may be required to insure proper indent.

To Reassemble — Follow reverse order. Make certain that extractor pivots freely. Split in firing pin stop pin should face up when reassembling into bolt. When assembling firing pin retaining pin make certain firing pin retractor spring locates to rear of retaining pin. Re-bend or replace retaining pin to hold securely in bolt.

ACTION SPRING PLUNGER— ACTION SPRING

To Disassemble — Cock rifle and push safety ON SAFE. Remove bolt handle, receiver cover assembly, barrel and barrel bracket assembly. Remove bolt assembly. Pull out action spring plunger and action spring from striker sleeve and remove from rifle.

To Reassemble — Follow reverse order.

FIRING PIN STRIKER

To Disassemble — Cock rifle and push safety ON SAFE. Remove bolt assembly. Remove action spring plunger and action spring. Push safety forward to FIRE position. Hold "cocked" firing pin striker against pressure of firing pin striker spring, then pull trigger to release cocked striker forward. Allow striker to ease forward until spring pressure is reduced. Pull striker forward and remove from rifle.

To Reassemble — (with sear assembled to rifle) Make certain striker spring sleeve and spring remains assembled to stock with flanged end to rear. Assemble firing pin striker to bolt rails in stock (with large hole diameter to rear). Slide striker rearward along bolt rails until striker spring re-enters spring hole at rear of striker. Continue pushing striker rearward until halted against sear — and hold. Pull trigger and hold. This will permit disconnecter to move forward and disengage sear. Press sear downward. Then push striker to rear and over sear. Release trigger. See Fig. 5. Releasing trigger permits disconnecter to move rearward again and re-engage sear. Sear in turn will then hold firing pin striker rearward and in "cocked" position.

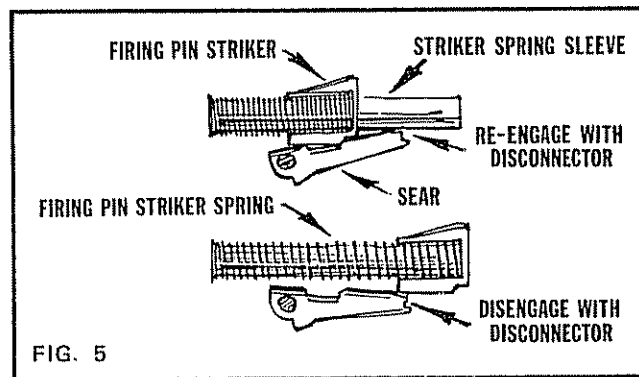

Push safety rearward to ON SAFE. Firing pin striker then cannot "uncock" or be released forward.

FIRING PIN STRIKER SPRING STRIKER SPRING SLEEVE

To Disassemble — Remove bolt assembly, firing pin striker, firing pin striker spring and striker spring sleeve from rifle.

To Reassemble — Follow reverse order. Make certain flanged end of striker spring sleeve is to rear in stock.

TRIGGER GUARD

To Disassemble — Cock rifle and push safety ON SAFE. Remove bolt handle and receiver cover assembly. Tap out trigger guard assembly pin. Pull trigger plate from bottom of stock.

To Reassemble — Follow reverse order.

NYLON 77

TRIGGER COMPLETE

To Disassemble — Cock rifle and push safety ON SAFE. Remove trigger guard. Unhook trigger spring from forward spur on trigger. Push out trigger assembly pin. Remove trigger assembly from stock.

To Reassemble — Locate trigger with trigger cap assembled to trigger notch in disconnecter bar. Check engagement through open hole in right side of stock. See Fig. 6.

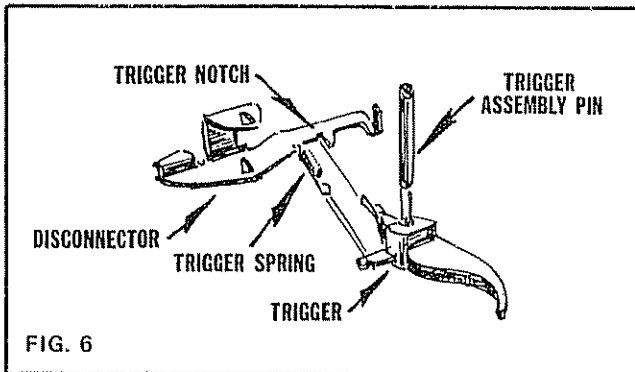

Align trigger to trigger assembly pinhole in stock, and tap in trigger assembly pin. Rehook front spur on trigger to trigger spring.

SEAR, SEAR SPRING (SEAR ASSEMBLY PIN)

To Disassemble — Cock rifle and push safety ON SAFE. Remove receiver cover assembly. Remove barrel, bolt assembly, firing pin striker, striker spring and sleeve. Remove outer magazine tube, and magazine tube assembly. Remove trigger guard, trigger complete. Reach into open top of stock and hold sear down. Then reach into open bottom of stock and push disconnecter pivot rearward. This will release sear upright in stock and remove tension on sear spring. Release disconnecter pivot. Tap out sear pin assembly.

NOTE: Take care that sear parts do not drop in butt stock cavity. Remove sear, sear spring.

To Reassemble — Assemble sear upright from open top of stock, and align with sear pinhole (use drift punch). Assemble sear spring to upright sear. Make sure that short end of sear spring assembles to sear notch front and tension-wise to safety lever pin at rear. Tap in sear assembly pin.

CAUTION: Make sure proper pin is used. Sear assembly pin can be mistaken for other pins of smaller diameter. Other pins of smaller and same diameter include: safety lever cam pin, trigger assembly pin, trigger guard assembly pin.

To position upright sear to level assembly location, reach in open bottom of stock and push disconnecter pivot rearward. Then turn upright sear downward until front end positions under disconnecter. Release disconnecter pivot to latch sear beneath disconnecter.

DISCONNECTOR ASSEMBLY is designed to make the trigger assembly **inoperative** — that is, "free-swinging" and out of contact with the disconnecter. This "out of contact" continues until the action is closed completely and the safety is pushed rearward to the FIRE position. Only then is the trigger operative and able to "pull" and complete the firing cycle.

To Disassemble — Cock rifle and push safety ON SAFE. Remove bolt handle and receiver cover assembly. Remove barrel, bolt assembly, firing pin striker, striker spring and sleeve. Remove trigger guard and trigger complete.

Reach into open top of stock and hold against sear, then reach into open bottom of stock and push disconnecter pivot rearward. This will release sear to upright position in stock. With small tool unhook front end of disconnecter pivot spring from nylon "bridge". Push in disconnecter pivot pin and disconnecter assembly will fall free and can be removed from stock. See Fig. 7.

To Replace — Replacement components interchangeable. No adjustment or factory assembly required. The disconnecter assembly is factory listed to include components of disconnecter, disconnecter pivot, disconnecter pivot spring, trigger spring.

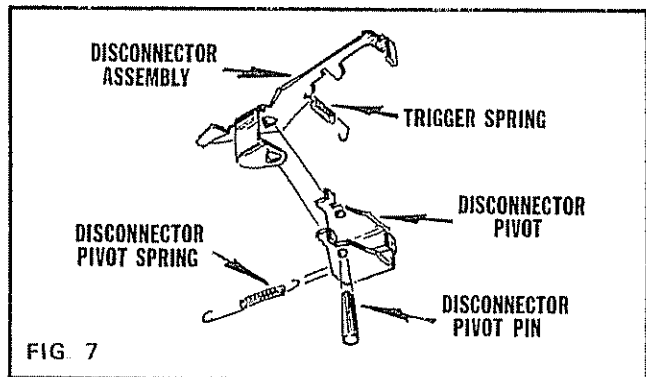

To Reassemble — Follow reverse order. Make sure rear of disconnecter assembles correctly behind upright sear and below shoulder in rear of stock. After hooking front loop of disconnecter pivot spring over nylon "bridge", push disconnecter pivot rearward and assemble upright sear to latch beneath disconnecter.

SAFETY ASSEMBLY is designed to raise disconnecter at rear and disengage from trigger when in rear or ON SAFE position. Forward or FIRE position re-engages disconnecter to trigger (red bottom showing).

To Disassemble — Cock rifle and push safety ON SAFE. Remove bolt handle and receiver cover assembly. Remove barrel, barrel bracket, bolt assembly, action spring, action spring plunger, firing pin striker, striker spring and sleeve. Remove trigger guard.

NOTE: Not necessary to remove safety detent retaining pin, safety detent spring, safety detent ball.

Turn rifle bottom up and tap out safety lever cam pin part way until clear of safety lever only. Cam pin should then hold sear spring under tension and in proper assembly. See Fig. 8. Safety assembly will be loosened.

Pull safety assembly and remove from top of stock.

To Replace — Interchangeable as replacement. No adjustment or factory assembly required. Replacement as an assembly recommended. Safety assembly is factory listed to include safety, safety lever, safety lever pin.

To Reassemble — Follow reverse order. Make certain front spur on safety lever assembles easily to properly lift rear of disconnecter from engagement with trigger cap. Long end of sear spring should locate to safety lever cam pin for tension purposes. See Fig. 8.

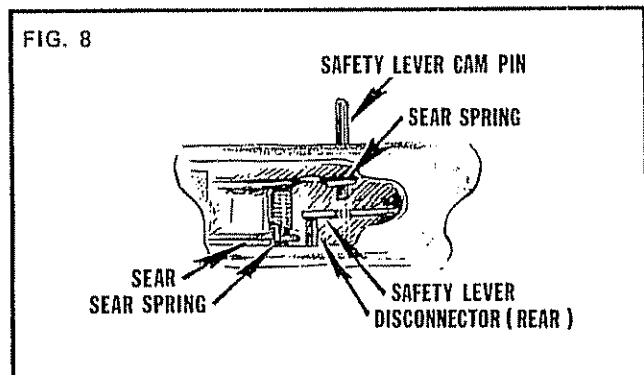

SAFETY DETENT BALL — SAFETY DETENT SPRING

To Disassemble — Remove bolt handle and receiver cover assembly. Pull safety detent retaining pin rearward and remove from stock.

CAUTION: Safety detent spring is under tension of retaining pin. Hold spring in place during removal of pin to prevent loss. Remove safety detent spring and underlying safety detent ball. See Fig. 9.

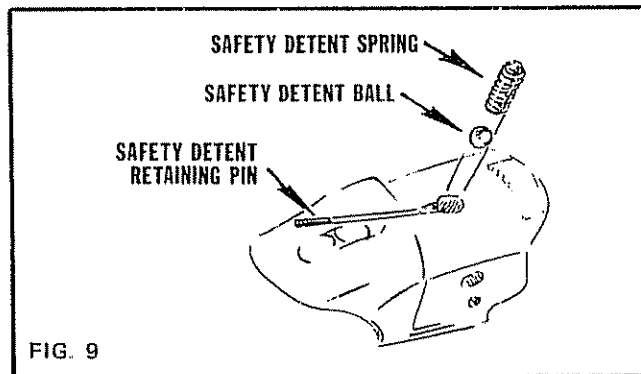

To Reassemble — Follow reverse order

STOCK ASSEMBLY designed to contain or mount all of the rifle parts for the Nylon 77. For finishing service see STOCK FINISHING.

To Disassemble — Remove all rifle parts. Do not remove stock nut (3) or bolt (3) — not necessary.

To Reassemble — Follow reverse order for reassembly of rifle parts.

REAR COVER SCREW BUSHING

To Disassemble — Remove bolt handle and receiver cover assembly. Tap out and remove rear cover screw bushing. Note visual shoulder of small inside diameter on right end (assembly position) of bushing.

To Reassemble — Follow reverse order. Make certain that bushing end with small inner diameter assembles to right side of stock.

MAGAZINE ASSEMBLY — includes magazine, magazine follower, magazine shoe, magazine side, magazine spring.

To Disassemble — Depress rear of magazine latch thumbpiece and pull magazine assembly (clip) from magazine guide.

To Reassemble — Follow reverse order.

MAGAZINE GUIDE, MAGAZINE LATCH, MAGAZINE LATCH THUMBPIECE AND MAGAZINE GUIDE SCREW

To Disassemble — Unscrew magazine guide screw and remove magazine guide and assembled magazine latch and thumbpiece. Bend ears of magazine latch outward until thumbpiece can be disassembled from latch.

To Reassemble — Follow reverse order.

MALFUNCTIONS

Cause and Correction

FAILS TO LOAD

- Cause:**
1. Cartridge feed guide damaged, binds.
 2. Firing pin damaged, binds.
 3. Barrel chamber fouled, rusty, damaged.
 4. Extractor cut in barrel damaged.
 5. Action fouled.
 6. Extractor damaged, binds cartridge in chamber in stemming position.
- Correction:**
1. Replace or free up.
 2. Replace or free up. Check protrusion (approximately .020") from extreme front face of bolt (firing pin held forward). Check firing pin retractor spring for damage or incorrect assembly (spring should be to rear of firing pin retaining pin). Chamfer firing pin slightly on bottom corner if necessary.
 3. Replace barrel or clean and polish, (slightly).
 4. Replace barrel or repair extractor cut.
 5. Clean action.
 6. Replace or free up extractor, plunger, and spring. Adjust tension on claw. Use fired case. Adjust space under claw (nominal) .050"

SAFETY WORKS HARD OR TOO FREELY

- Cause:**
1. Safety assembly damaged. Assembly includes safety, safety lever, safety lever pin.
 2. Safety lever incorrectly assembled.
 3. Safety parts damaged, missing.
- Correction:**
1. Replace damaged part.
 2. Assemble correctly under rear of disconnecter.
 3. Replace safety detent ball, safety detent spring, safety detent retaining pin, safety lever cam pin.

REMINGTON FIELD SERVICE MANUAL

View No.	Part No.	NAME OF PART	View No.	Part No.	NAME OF PART
1	16511	Action Spring	28	14748	Magazine Guide
2	16544	Action Spring Plunger	29	14354	Magazine Guide Screw
3	16570	Barrel	30	14351	Magazine Latch
4	15045	Barrel Bracket	31	14957	Magazine Latch Thumbpiece
	25640	Barrel Bracket Assembly (includes Barrel Bracket, Barrel Support)	32	16748	Rear Cover Screw Bushing
5	15046	Barrel Support		24400	Rear Sight Assembly (includes Rear Sight, Elevation Screw, Elevation Screw Washer)
6	16512	Barrel Lock Screw	33	16528	Rear Sight Rivet
7	31620	Bolt Sub Assembly	34	24410	Receiver Cover Assembly (includes Cartridge Feed Guide Spring, Cartridge Feed Guide Spring Rivet, Receiver Cover Screw Lug (2), Receiver Cover Shell, Rear Sight, Rear Sight Rivet, Elevation Screw, Elevation Screw Washer, Windage Screw)
	24391	Bolt Assembly (includes Bolt Sub Assembly, Bolt Guide, Cartridge Feed Guide, Extractor, Extractor Plunger, Extractor Spring, Firing Pin, Firing Pin Retaining Pin, Firing Pin Retractor Spring, Firing Pin Stop Pin)	35	16530	Safety
8	16550	Bolt Handle		24405	Safety Lever Assembly
9	16547	Cartridge Feed Guide	36	16566	Safety Lever
	24415	Cartridge Feed Guide Spring Assembly (includes Cartridge Feed Guide Spring, Cartridge Feed Guide Spring Rivet)	37	16541	Safety Lever Cam Pin
10	16515	Cover Screw (2)	38	16531	Safety Lever Pin
11	16564	Disconnecter	39	23224	Safety Detent Ball
	25000	Disconnecter Assembly	40	16542	Safety Detent Retaining Pin
12	16565	Disconnecter Pivot	41	16533	Safety Detent Spring
13	16516	Disconnecter Pivot Spring	42	16567	Sear
14	16541	Disconnecter Pivot Pin	43	16534	Sear Assembly Pin
15	16519	Ejector	44	16559	Sear Spring
	16526	Elevation Screw (Range)	45	31625	Stock Assembly (includes Butt Plate, Butt Plate Spacer, Diamond Inlay—Right, Diamond Inlay—Left, Fore-end Tip, Fore-end Tip Spacer, Grip Cap, Grip Cap Spacer, Magazine Guide Nut, Stock Bolt (3), Stock—Right Half, Stock—Left Half, Stock Filler, Stock Nut (3))
	16527	Elevation Screw Washer	46	16540	Striker Spring Sleeve
16	18408	Extractor	47	16568	Trigger Complete (includes Trigger Cap)
17	17667	Extractor Plunger	48	16541	Trigger Assembly Pin
18	15006	Extractor Spring	49	14349	Trigger Guard
19	28185	Firing Pin	50	16541	Trigger Guard Assembly Pin
	28186	Firing Pin (size 6)	51	16517	Trigger Spring
	28184	Firing Pin (size 4)	52	16529	Windage Screw
20	16549	Firing Pin Retaining Pin			ACCESSORIES (Not Shown)
21	16513	Firing Pin Retractor Pin	25886		Sling Strap Assembly
	16514	Firing Pin Stop	15505		Sling Retaining Screw (need 4)
22	16554	Firing Pin Striker	15050		Sling Swivel Retainer (need 2)
23	16520	Firing Pin Striker Spring	26170		Sling Strap Assembly and Mountings Complete (includes Sling Strap Assembly, Sling Swivel Retainer (2), Swivel Retaining Screw (4))
24	16545	Front Sight	32341		10-Shot Magazine Assembly
25	16892	Front Sight Screw (2)			
26	16968	Front Sight Washer (2)			
27	32340	Magazine Assembly, 5-Shot (includes Magazine, Magazine Follower, Magazine Shoe, Magazine Side, Magazine Spring)			

DELIVERIES ARE F O B ILION, N Y

PARTS SUBJECT TO CHANGE WITHOUT NOTICE

REMINGTON FIELD SERVICE MANUAL

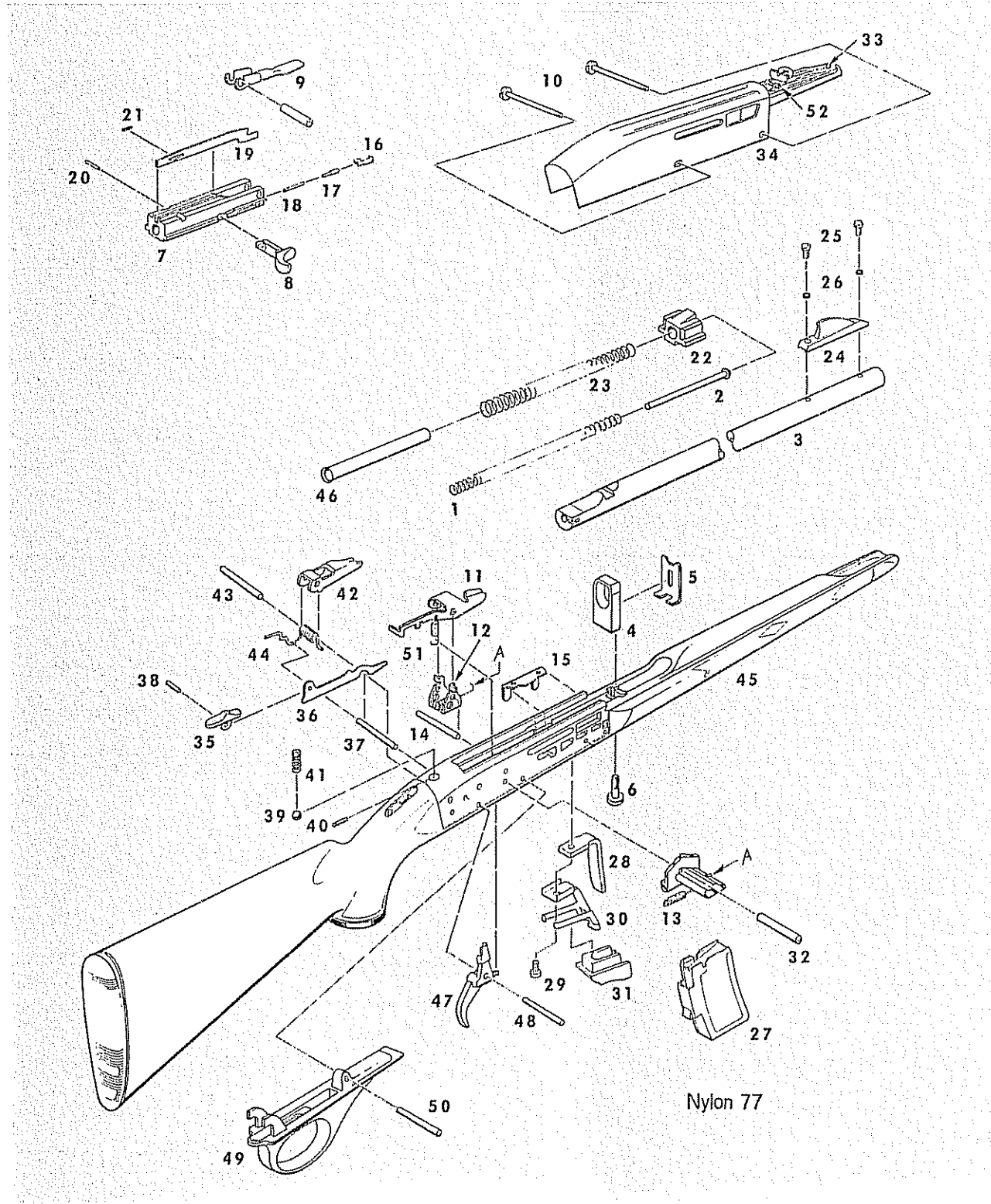

MALFUNCTIONS

CAUSE and CORRECTION

(Con't. from Page 4)

MISFIRES

- Cause:**
1. Trigger damaged (includes trigger and cap).
 2. Trigger spring damaged or disengaged.
 3. Firing pin damaged, binds, protrudes short
 4. Disconnecter damaged binds.
 5. Disconnecter pivot damaged, disengaged.
 6. Disconnecter pivot pin missing.
 7. Disconnecter pivot spring damaged, dislocated.
 8. Sear — sear spring damaged.
 9. Firing pin striker spring damaged.
 10. Extractor damaged, binds
 11. Cartridge chamber in barrel damaged, fouled, rusty
 12. Safety lever damaged, binds
 13. Ammunition faulty.

- Correction:**
1. Replace trigger complete
 2. Replace or assemble properly to trigger or disconnecter
 3. Replace or free up. Check for proper and "free" assembly of firing pin retractor spring to rear of assembled firing pin retaining pin. Check protrusion — approximately .020" (nominal) (from face of bolt).
 4. Replace or free up. Check notch engagement to trigger cap through hole in right side of stock.
 5. Replace or assemble correctly to disconnecter.
 6. Replace pin.
 7. Replace spring or assemble correctly to pivot and nylon stock bridge at front
 8. Replace
 9. Replace.
 10. Replace or adjust.
 11. Replace barrel or clean and polish chamber lightly
 12. Replace or free up
 13. Replace ammunition.

FAILS TO UNLOCK

- Cause:**
1. Cartridge chamber in barrel damaged, fouled, rusty.
 2. Action binds, damaged
 3. Extractor damaged, out of adjustment
 4. Ejector damaged, binds bolt

- Correction:**
1. Replace barrel or clean chamber, polish lightly.
 2. Clean action, check for damage to parts.
 3. Replace or adjust and free up.
 4. Replace or free up

DOUBLES (Fires automatically)

- Cause:**
1. Trigger damaged, binds.
 2. Sear notch damaged.
 3. Trigger spring damaged, missing, out of engagement.
 4. Sear spring damaged, dislocated
 5. Disconnecter assembly damaged, dislocated.

- Correction:**
1. Replace or free up. Check notch engagement to disconnecter
 2. Replace or repair notch. Check engagement to disconnecter.
 3. Replace or assemble to trigger and disconnecter properly. Check movement of trigger cap to disconnecter notch, engagement under tension of trigger spring
 4. Replace or assemble properly. Short end of spring to sear and long end below safety cam pin at rear.
 5. Replace disconnecter, disconnecter pivot, disconnecter pivot spring or adjust. Check pivot pin.

FAILS TO LOCK

- Cause:**
1. Ejector damaged
 2. Stock broken or cracked at bolt clearance slot.
 3. Action fouled, binds.
 4. Barrel chamber damaged, rusted, fouled.
 5. Ammunition faulty.
 6. Action spring damaged

- Correction:**
1. Replace ejector.
 2. Replace stock.
 3. Clean action, free up.
 4. Replace barrel, Repair extractor cut. Clean and polish chamber lightly
 5. Replace ammunition.
 6. Replace.

FAILS TO GROUP

- Cause:**
1. Barrel damaged.
 2. Barrel loose in take down.
 3. Sights loose.

- Correction:**
1. Replace barrel.
 2. Tighten barrel lock screw.
 3. Replace or tighten.

FAILS TO FEED

- Cause:**
1. Cartridge stop damaged, binds.
 2. Cartridge stop spring damaged, dislocated.
 3. Extractor damaged, binds.
 4. Cartridge feed insert damaged, dislocated.
 5. Magazine assembly, damaged, follower binds.

- Correction:**
1. Replace or clean and free up
 2. Replace or assemble correctly to support cartridge stop and cartridge feed insert.
 3. Replace or free up. Check extractor for proper chamber on bottom of claw. Check extractor plunger and spring for "free" movement.
 4. Replace or assemble correctly. Check for support from beneath by cartridge stop spring.
 5. Replace magazine assembly or free up follower. Check magazine spring for damage. Clean or replace spring.

FAILS TO EXTRACT

- Cause:**
1. Extractor damaged, missing, out of adjustment.
 2. Extractor cut in barrel damaged.
 3. Cartridge chamber in barrel damaged, fouled, rusty.
 4. Action binds, fouled, damaged.

- Correction:**
1. Replace or free up and adjust for proper tension. Use fired case. Check extractor plunger and spring.
 2. Replace barrel or repair cut.
 3. Replace barrel or clean, polish chamber lightly.
 4. Free up action, clean and check for damaged parts.

FAILS TO EJECT

- Cause:**
1. Ejector damaged, missing.
 2. Extractor, extractor plunger, extractor spring damaged, binds
 3. Firing pin damaged, binds.
 4. Cartridge chamber in barrel damaged, rusty, fouled.
 5. Extractor cut in barrel damaged.

- Correction:**
1. Replace or repair.
 2. Replace or free up and adjust for proper tension.
 3. Replace or free up and check excessive protrusion.
 4. Replace barrel or clean and polish lightly.
 5. Replace barrel or repair extractor cut

STOCK

Listed below is the recommended method of restoring the finish on the Nylon's stock.

Scratches: Use finely powdered pumice stone and oil. Rub with felt pad. Wipe clean and dry.

Abrasion: Use Du Pont auto rubbing compound. Rub with cloth pad. Wipe clean and dry.

For Polishing: Use Du Pont Auto waxes.

To Clean Checkering (and Striations): Use stiff tooth brush

Listed below is the recommended method of servicing for butt plates, grip caps, etc.

CAUTION: Phenol is used in the weld assembly of nylon components. Use all necessary acid handling precautions.

Follow numbered sequences:

1. Swab both joining surfaces with phenol. Take care that acid is applied to contact surfaces only.
2. Two (2) applications should be sufficient.
3. Allow swabbed surfaces to saturate thoroughly for at least five (5) minutes before joining.
4. Join saturated surfaces and hold in place. Use tape or clamps

NOTE: Care should be taken that acid in excess is not applied to joining surfaces. Excess acid, squeezed or extruded from joined surfaces, must be removed immediately. Blemished areas will appear on unjoined areas if acid saturation is allowed to develop.

5. Allow at least one (1) hour for joined surfaces to weld together. Then remove tape or clamps. To remove slight abrasions or blemished in weld areas, use a good grade of auto rubbing compound.

CYCLE OF OPERATION

The Remington Nylon 77 is an autoloading 22 caliber rim fire rifle designed to operate with long rifle cartridges only. A clip magazine that loads from the bottom of receiver has a capacity of five (5) cartridges. The rifle may be single loaded by rotating rifle until ejection port faces up and then placing cartridge on the bolt through ejection port. Cartridge is then loaded by rapidly pulling bolt handle rearward and releasing.

A special nylon sling strap can be attached as optional equipment.

Clip magazine may easily be removed by pressing rear of magazine latch thumbpiece and pulling clip out of receiver. Cartridges may be removed from clip by sliding forward and out. Chamber is emptied by opening and closing action.

NYLON 77

SAFETY

When pushed forward, the thumb operated safety places rifle in FIRE position. A red dot is visible to rear of safety. A rearward motion places safety on SAFE position. With safety in this position, red dot is **not visible**.

On Safe: Rearward motion of safety raises disconnecter (by the safety lever) from a notching contact with trigger. The trigger is then free swinging and **cannot fire** rifle.

Fire: Forward movement of safety pushes safety lever from beneath the upheld disconnecter and permits disconnecter to be drawn down by trigger spring to again connect with trigger to fire rifle.

FIRING

Pulling of trigger releases a spring loaded firing pin striker forward to strike against the firing pin. When struck, the firing pin will complete firing cycle by indenting and firing the round. With safety pushed forward to FIRE position (red dot showing) trigger can be pulled each time to fire round. When pulled, trigger rotates upon trigger assembly pin-pushing disconnecter forward against back pressure of spring-loaded disconnecter pivot. With disconnecter pushed forward, sear is unlatched from disconnecter. Disengaged sear is then cammed downward by spring pressure of the forward moving striker. The striker then passes swiftly over sear and strikes firing pin. The firing pin has a free limited movement within the bolt assembly. When struck by the swiftly moving striker, the firing pin transmits the blow from striker to indent and fires cartridge.

UNLOCKING

This rifle is operated by the so-called "blow back" system. The only unlocking that can be classed as a cycle is the build-up of a combustion force to overcome the inertia of the closed bolt and firing pin striker. Resistance is also created by the action spring against bolt and the striker spring against striker. This resistance must also be overcome by the combustion force.

EXTRACTION

The extraction cycle is the properly timed "blow back" of the fired cartridge case from the barrel chamber. After firing, a brief time interval exists as bullet leaves muzzle. Combustion pressures then subside, permitting cartridge case to relax from against chamber wall.

Reduced combustion pressure (or extraction forces) drives fired cartridge case rearward. This motion forces bolt assembly and firing pin striker away from barrel breech, carrying fired case with it. The fired case, securely positioned and aligned on bolt face by extractor, is thus forced from barrel chamber. These "extraction forces" are slowed as the action and striker springs are compressed. Energy from the compressed action spring is available to close action during loading cycle.

NOTE: Extractor grips rim of unfired cartridge to extract round from chamber.

EJECTION

The ejector, located in the stock, intercepts rim of fired case as extraction cycle is completed. When this interception is made, the opposing grip of extractor claw pivots fired cartridge case away from bolt and out the ejection port.

COCKING

This cycle is the combined holding back of firing pin striker by the sear and the latching upward of sear against spring-loaded striker by disconnecter.

The bolt assembly is blown back by extracting cartridge case. The firing pin striker, which is in the forward position against the bolt assembly, is also forced back. As the bolt assembly starts back, contact is made with a cam on front of disconnecter. The camming contact disengages trigger from a notched position with disconnecter. This disengagement of trigger and disconnecter prevents repeat firing until action is (1) fully closed, and (2) the trigger released to re-enter "notched" position with disconnecter for the next pull of trigger.

The sear meanwhile is pressed upward against the bottom of the rearward-moving striker. The sear continues to press against striker until the inclined engaging shoulder on striker permits sear to raise further and intercept the return travel of striker.

The disconnecter, under constant back pressure from the disconnecter pivot, then slips back and under raising sear. This under, or "latching", engagement of disconnecter with sear prevents striker from forcing sear downward again until trigger is (1) renotched to disconnecter, and (2) pulled to fire. This "renotching" of trigger cannot occur until bolt assembly is fully forward again and free of cam contact with front end of disconnecter.

The trigger spring joins trigger and disconnecter. This insures a full and complete renotching engagement of trigger and disconnecter for the next pull of trigger to fire rifle.

FEEDING

The feeding cycle is the upward urging of cartridge by magazine spring and follower. Cartridge is held in loading position by feed lips and follower on magazine.

LOADING

In the loading cycle, the cartridge is "picked up" and fed into the barrel chamber by the closing bolt.

LOCKING

The only locking in an action of this blow-back type is the backing up of the chambered cartridge by the weight of the closed bolt and forward position of the firing pin striker. Two springs, the action and striker spring, back up the closed bolt and forward striker.

A spring-tensed extractor, during this locking cycle, is channeled into an inclined breech cut. This inclined positioning of the extractor, over the rim of the loaded cartridge, permits the claw of the extractor to locate securely against the rim during extraction.